

SEMI AUTOMATIC

**SYNTHESI**

**MAINTENANCE FREE MACHINES  
EASY TO BE INSTALLED**

Atlanta Stretch S.p.A - Italy  
Atlanta Deutschland GmbH  
Atlanta Iberica - Spain  
Atlanta Packaging Ltd - UK  
Atlanta France Sarl  
Atlanta Stretch Australia  
Atlanta Stretch Russia



**ATLANTA**  
S T R E T C H

stretch wrapping machines specialist



[www.atlantastretch.com](http://www.atlantastretch.com)

**IT\_** Synthesi si caratterizza per l'utilizzo e l'applicazione del film estensibile già prestirato e per le sue funzioni semplificate.

**EN\_** Synthesi is characterised by the use and application of already pre-stretch film and its simplified functions.

**FR\_** Synthesi se caractérise pour l'utilisation et l'application de film pré-étiré et par ses fonctions simples mais complètes.

**DE\_** Synthesi wird durch den Gebrauch von Vorgedehnter Stretchfolien und das Bedienpult mit einfacher Funktionen gekennzeichnet.

**ES\_** Synthesi se caracteriza por la utilización y aplicación de film pre-estirado y por su simplificación de funciones.



## OPTIONAL: LOW PROFILE

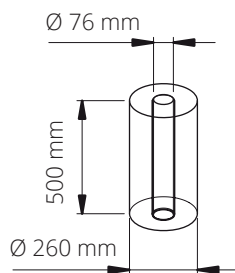
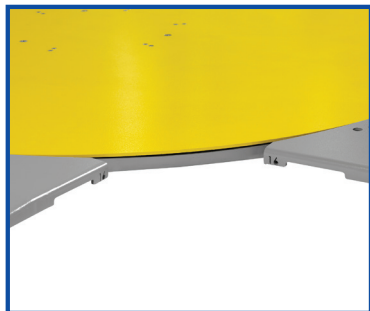

**IT\_** Basamento basso profilo per transpallet manuale.

**EN\_** Low profile basement for manual lifter.

**FR\_** Châssis extra fin pour transpalette manuel.

**DE\_** Flaches Drehtellergestell für Handhubwagen.

**ES\_** Base con perfil bajo especial para transpaletas.

### Pallet dimension

Ø 1500 Max 800x1200 mm

Ø 1650 Max 1000x1200 mm

### Pallet

Max weight 2000 kg



- IT\_ Versione transpallet a 3 vie di carico.
- EN\_ Transpallet version with 3 in feed.
- FR\_ Version transpalette 3 voies.
- DE\_ Ausführung Transpallet mit 3 ladenmöglichkeiten
- ES\_ Version transpallet 3 posiciones de carga.

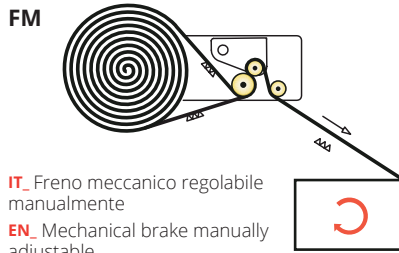
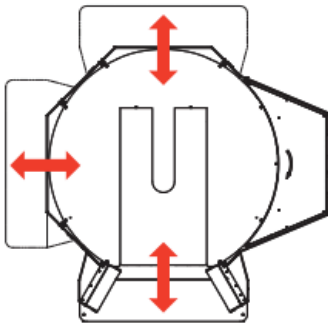

- IT\_ Freno meccanico regolabile manualmente
- EN\_ Mechanical brake manually adjustable.
- FR\_ Frein mécanique sur rouleau de détournement ajustable manuellement.
- DE\_ Mechanische Bremse auf Umlenkwalze.
- ES\_ Fricción mecánica regulable manualmente.



**Pallet dimension**  
 Ø 1650 1000x1200 mm  
 Max height 2200 mm

**Pallet**  
 Max weight 1200 kg

## SYNTHEsi / SYNTHEsi TP

### TECHNICAL CHARACTERISTICS / BASIC MACHINE

Total installed power	1.00 Kw
Standard input voltage	230V mono-phase - 50/60 Hz
Electrical system and motors protection	IP 54
Standard pallet height	2200 mm
Max pallet dimensions	1000 x 1200 mm ( <b>TP</b> 1000 x 1200 mm)
Max loading weight	2000 Kg ( <b>TP</b> 1200 Kg)
Table diameter	ø 1500 / ø 1650 mm ( <b>TP</b> ø 1650 mm)

## EASY INSTALLATION

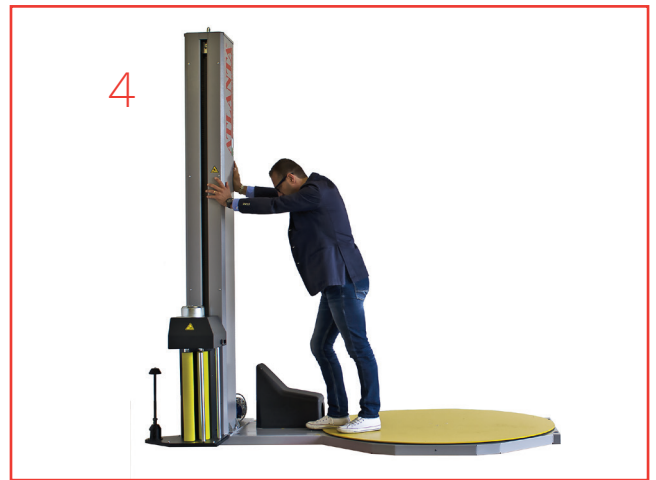
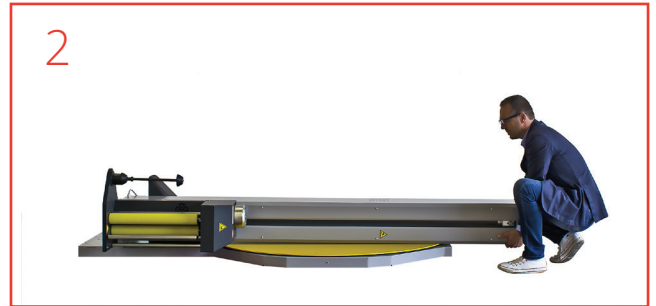
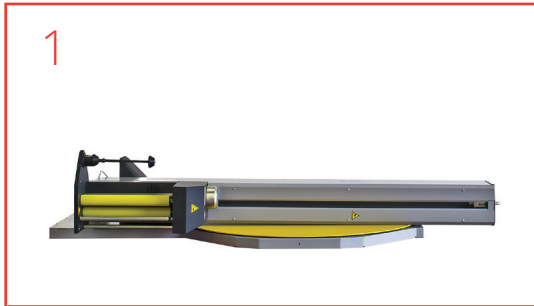

■ Atlanta Stretch S.p.A  
Via Chiesa di Camerano, 30  
47824 Poggio Torriana (Rimini) Italia  
Tel. +39 0541 627145  
Fax +39 0541 627220  
www.atlantastretch.com  
sales@atlantastretch.com

**ATLANTA**  
S T R E T C H  
stretch wrapping machines specialist