



IT\_ Pressore tenuta pallet.  
 EN\_ Pallet holder presser.  
 FR\_ Plateau stabilisateur de charge.  
 DE\_ Palettendruckhalter.  
 ES\_ Prensor retención palet.



IT\_ Sistema di pesatura integrato.  
 EN\_ Integrated weighing systems.  
 FR\_ Pesage intégré.  
 DE\_ Integrierte Waagesysteme.  
 ES\_ Sistema integrado de pesaje.



IT\_ Controllo peso film.  
 EN\_ Film weight check.  
 FR\_ Calcul poids de film.  
 DE\_ Kontrolle Foliengewicht.  
 ES\_ Control peso film.



IT\_ Sistema di taglio automatico del film a fine ciclo.  
 EN\_ Automatic Film cutting device at cycle end.  
 FR\_ Coupe automatique du film.  
 DE\_ Automatische Folienschneidvorrichtung am Zyklusende.  
 ES\_ Sistema automático de corte film con fin de ciclo.



IT\_ Colonna per carichi fino a 3700 mm.  
 EN\_ Mast for loads up to 3700 mm high.  
 FR\_ Colonne pour charges jusqu'à 3700 mm.  
 DE\_ Mast für Ladungen bis 3700 mm hoch.  
 ES\_ Columna para cargas de hasta 3700 mm.



IT\_ Sistema d'imballo per porte e finestre.  
 EN\_ Wrapping System for doors and windows.  
 FR\_ Système d'emballage pour portes et fenêtres.  
 DE\_ Wickelsysteme für Fenster und Türen.  
 ES\_ Sistema de embalaje para puertas y ventanas.



IT\_ Rulliera non motorizzata.  
 EN\_ Non-motorized roller conveyor.  
 FR\_ Non-motorisés à rouleaux.  
 DE\_ Nicht-Motorisierte Rollenbahn.  
 ES\_ Rodillos no motorizados.



IT\_ Sistema di cordonatura film: Permette di ridurre l'altezza del film formando un cordone che assicura una più efficiente stabilizzazione del carico.  
 EN\_ Roping System: Reducing the film width to form a rope to ensure more effective load stabilisation.  
 FR\_ Systeme permettant de réduire la laize du film en formant un cordon qui assure une meilleure stabilisation de la charge.  
 DE\_ Schnurrvorrichtung: Reduzierung der Folienbreite zur Schnur um eine bessere Stabilisierung der Ladung zu gewährleisten.  
 ES\_ Sistema de Cordón. Permite reducir la altura del film formando un cordón que asegura con mas eficacia la estabilidad de la carga.

13000035826-LR0319 - Le indicazioni riportate non sono impegnative. The information given is not binding. Les indications fournies ne sont pas contraignantes. Die Angaben sind unverbindlich. Las indicaciones presentadas no nos comprometen.

SEMI AUTOMATIC

SYNTHEX

EASILY INSTALLED  
MAINTENANCE FREE MACHINES

Atlanta Stretch S.p.A - Italy  
 Atlanta Stretch Deutschland GmbH  
 Atlanta Stretch Iberica - Spain  
 Atlanta Packaging Ltd - UK  
 Atlanta Stretch France Sarl  
 Atlanta Stretch Australia  
 Atlanta Stretch Russia  
 Atlanta Stretch Turkey



**ATLANTA**  
 S T R E T C H  
 stretch wrapping machines specialist



www.atlantastretch.com

Atlanta Stretch S.p.A

Via Torrianese, 58 - 47824 Poggio Torriana (Rimini) Italia  
 Tel. +39 0541 627145 - Fax +39 0541 627220  
 www.atlantastretch.com - sales@atlantastretch.com

**ATLANTA**  
 S T R E T C H  
 stretch wrapping machines specialist

**IT\_** La macchina SYNTHEX può utilizzare film estensibile ad alto pre-stiro per ridurre i costi di utilizzo della macchina stessa.

**EN\_** Synthex is characterised by the use of power pre-stretch film, to reduce the cost of ownership.

**FR\_** Synthex se caractérise par l'utilisation de film à pré-étirer pour réduire les coûts.

**DE\_** Synthex zeichnet sich durch die Verwendung von Power-Pre-Stretch-Folie aus, um die Betriebskosten zu senken.

**ES\_** Synthex se caracteriza por el uso de film de preestiro, reduciendo el coste de adquisición, al amortizar antes la inversión.

**Pallet dimension**

- Ø 1500 Max 800x1200 mm
- Ø 1650 Max 1000x1200 mm
- Ø 1800 Max 1200x1200 mm
- Ø 2200 Max 1500x1500 mm
- Ø 2400 Max 1650x1650 mm

**Pallet weight** Max 2000 kg

- IT\_** Rampa di carico.
- EN\_** Loading ramp.
- FR\_** Rampe.
- DE\_** Ladungsrampe
- ES\_** Rampa de carga.



**IT\_** Basamento basso profilo per transpallet manuale. Altezza da terra di soli 25 mm!

**EN\_** Low profile 25mm high turntable, designed to ease manual loading!

**FR\_** Châssis extra fin pour transpalette manuel. Hauteur de seulement 25mm!

**DE\_** Flaches Drehtellergestell für Handhubwagen, Höhe nur 25 mm!

**ES\_** Base con perfil bajo especial para transpaletas. Altura solo 25 mm!



**Pallet weight** Max 1200 kg

**Pallet dimension**  
Ø 1650 Max 1200x1200 mm

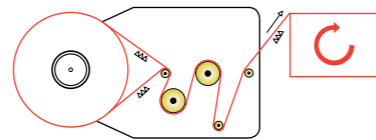
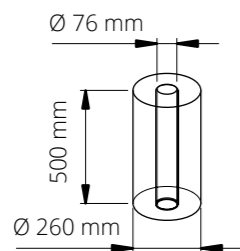
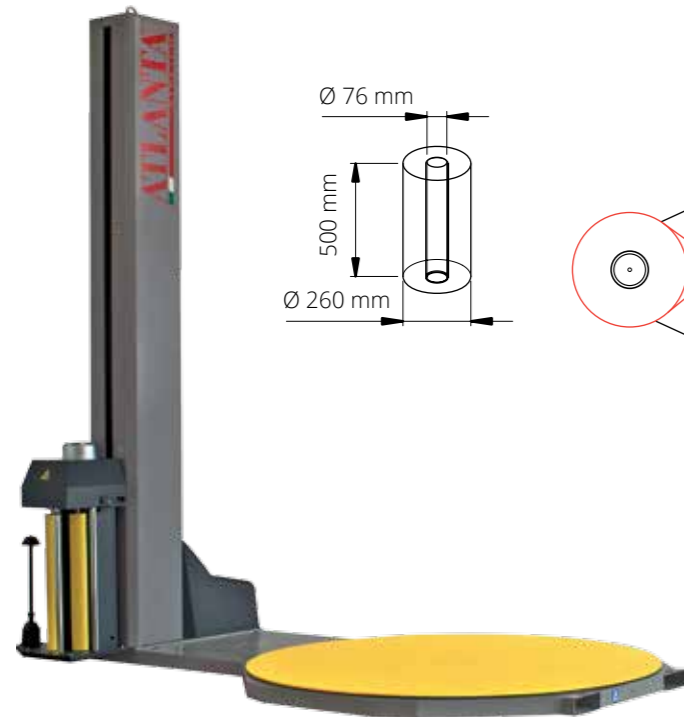
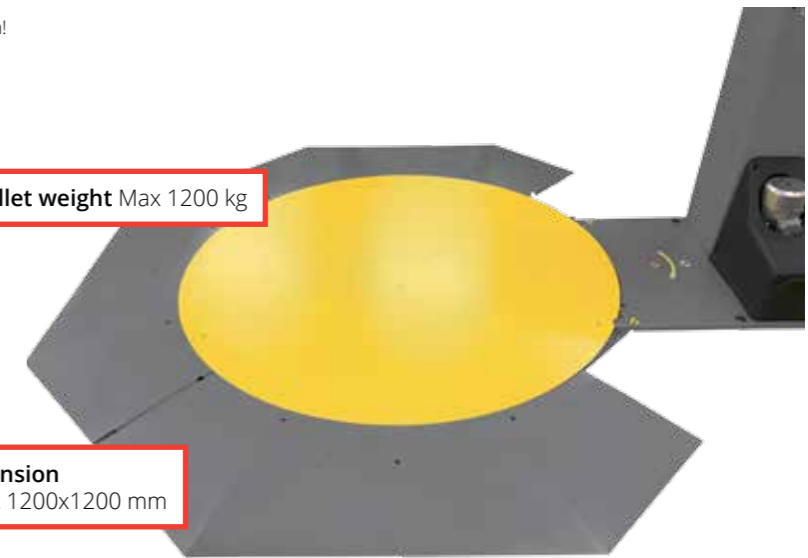

**OPS ONE PRE STRETCH**

**IT\_** Sistema di pre-stiro motorizzato a 2 rulli comandato elettronicamente con rapporti intercambiabili: 150 - 200 - 250%.

**EN\_** Motorised pre-stretch system including 2 electronically driven rollers with interchangeable ratios: 150 - 200 - 250%.

**FR\_** Système de pré-étirage motorisé et asservi à 2 rouleaux, rapports interchangeables: 150 - 200 - 250%.

**DE\_** Angetriebener Vordehnssystem mit 2 Vordehnrollen, elektronisch gesteuert mit leicht wechselbarer Zahnradsätzen: 150 - 200 - 250%.

**ES\_** Sistema de preestiro motorizado con 2 rodillos, comandado electrónicamente con desarrollos intercambiables: 150 - 200 - 250%.

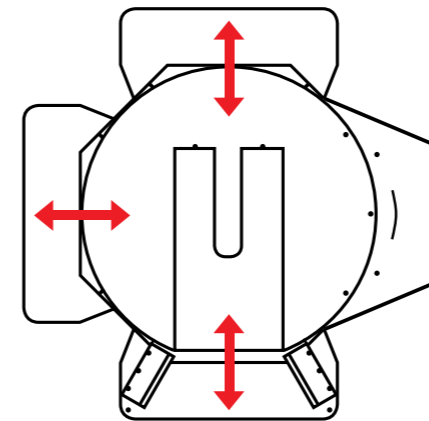

**Pallet dimension**  
Ø 1650 Max 1200x1200 mm  
Ø 1650 Max 1200x1200 mm

**Pallet weight** Max 1200 kg

- IT\_** Versione transpallet con 3 possibili vie di carico.
- EN\_** Transpallet version with 3 in-feeds.
- FR\_** Version transpalette 3 voies.
- DE\_** Ausführung Transpallet mit 3 ladenmöglichkeiten.
- ES\_** Version traspallet 3 posiciones de carga.



**IT\_** Touch screen 11" Pannello operatore con 3 + 1 programmi di avvolgimento e selezione dei parametri quali: giri alti e bassi, velocità di rotazione, sovrapposizione film in salita ed in discesa, stop per top cover e programma con fermata programmata in altezza.

**EN\_** The touch screen 11" operating panel, has 3 + 1 selectable programs and a range of parameters including, bottom & top wraps, speed of rotation, speed of carriage movement up & down. It also has independently adjustable, top-sheet & height setting programs.

**FR\_** Touch screen 11" Pupitre opérateur avec 3 + 1 programme sélectionnable et des paramètres tels que cycle montée et descente, vitesse de rotation, vitesse du chariot ajustable et indépendante pendant la montée et la descente, dépose de coiffe et hauteur fixe et paramétrable.

**DE\_** Touch screen 11" Bediendisplay mit 3 + 1 wählbaren Programmen sowie folgenden Einstellungsmöglichkeiten: Fuß- & Kopfwicklungen, Dreharmgeschwindigkeit, Hubschlittengeschwindigkeit, Foliendeckblattfunktion sowie Höhe über absolut Maß.

**ES\_** Pantalla táctil de 11" Panel operativo con diferentes programas seleccionables (3+1) y otros parámetros opcionales tales como envoltura de refuerzo en la parte superior e inferior, velocidad de rotación, velocidad de movimiento del carro hacia arriba y hacia abajo ajustable de manera individualizada, programa de aplicación de lámina "top-cover" y de lectura de la altura.



**Display**  
touch-screen 11"  
easy to use

**TECHNICAL CHARACTERISTICS / BASIC MACHINE**

Total installed power	1.5 Kw
Standard input voltage	230V mono-phase - 50/60 Hz
Standard pallet height	2200 mm
Optional pallet height	2700 mm / 3000 mm / 3300 mm / 3700 mm
Max pallet dimensions	1000 x 1200 mm ( <b>TP</b> 1000 x 1200 mm)
Max loading weight	2000 Kg ( <b>TP</b> 1200 Kg)
Table diameter	Ø 1650 / 1800 mm / 2200 mm / 2400 mm
Table diameter <b>TP</b>	Ø 1650 / 1800 mm